

# Ultrasound detection of wall-travelling bubbles for diagnosis of drag reduction

Hyun Jin Park, Hirohide Kayukawa, Yoshihiko Oishi, Yuji Tasaka and Yuichi Murai  
Lab. for Flow Control, Graduate School of Engineering, Hokkaido Univ., Sapporo 060-8628, Japan



Bubbles injected into a turbulent boundary layer reduce a wall friction. The bubble drag reduction is not adopted yet practically at vessels because of unstable performance. We invented a new method to promote drag reduction by giving a fluctuation on local void fraction. To keep the higher performance, maintaining the fluctuation is required until the afterpart of vessels. We design a system for detecting bubbles that is applicable for actual ships by analyzing ultrasound echo signal to investigate states of advection bubbles. For the first step, we discuss accuracy of the system comparing with detecting bubbles by a camera. Then, advection bubbles in channel flows of the tap water and surfactant solution are investigated statistically by this system at three locations in downstream from the injection point. Bubbles are advected randomly on downstream region in the tap water. On the other hand, the surfactant maintains states of a bubbly flow, e.g. fluctuation of void fraction, etc., from an upstream region to a downstream region by preventing coalescence of bubbles. From the results, promoting drag reduction by the fluctuation of void fraction is expected when coalescence of bubbles is prevented.

**Keywords:** Bubble cluster, channel flow, ultrasonic bubble detection, statistics

## 1 INTRODUCTION

Bubbles injected into a turbulent boundary layer reduce wall friction. It is respected as one of techniques to decrease fuel consumption of low-speed huge vessels, because the friction drag acting on these vessels occupies 80 % of the total drag. Since this technique was invented at 1973, it has been investigated by laboratory scale experiments of many institutes over 40 years and the results were recently summarized by Ceccio (2010) [1]. His review alludes that it is feasibly practical although the underlying phenomena is still unsolved comprehensively. To confirm practicalness of injecting bubbles for drag reduction at real situations, full scale experiments were also done using an actual ship in Japan and about 5 % improvement on the net efficiency of the ship was reported [2].

The authors' group has studied to understand mechanisms of the bubble drag reduction for improving its performance, where UVP has been used as one of powerful tool to investigate influence of bubbles on the flows. We concluded a wavy supply of bubbles (corresponding to forced fluctuation of local void fraction) enhances the drag reduction in the same gas flow rate for continuous injections [3, 4]. To keep the higher performance, maintaining the fluctuation of void fraction in the long range beneath the ship, from the front to rear of the ship, is required. It is hard to expect how bubbles are advected beneath the ship from results of laboratory scale experiments because of huge scale gaps with the real situations. To investigate this, non-intrusive measurement tools are required to avoid physical damage on the tools and disturbing the flows. Hence, an ultrasonic transducer, which has good

durability and was used in actual vessel [5], is selected to measure bubble's advection behaviors. Before a practical use in the vessel, a laboratory experiment using a channel flow is performed. In this paper, we discuss how to detect bubbles by echo signal of ultrasound and how bubbles are advected in the channel flow. By investigating state of advection bubbles at several locations on a downstream of the channel flow, sustainability of artificial fluctuation of void fraction is possible to be estimated.

## 2 EXPERIMENTAL SETUP

Figure 1 shows the schematic diagram of the experimental apparatus. The test section is a horizontal rectangular channel, which is made of transparent acrylic resin, and is 40 mm in height ( $H = 2h$ ), 160 mm in width, and 6000 mm in length, 10 mm in wall thickness, respectively. A bulk Reynolds number defined by the half height of the channel is 23000 and the flow in the channel is turbulent. Two kinds of working fluid are used in the experiment; one is tap water and the other is aqueous solution of 1-Pentanol, a kind of surfactant. Sea water prevents coalescence of bubbles. The surfactant solution also exerts the similar influence on bubbles in the solution [6]. Concentration of 1-Pentanol solution is 150 ppm. It is employed to ignore bubble behavior caused by different surface tension between two working fluids. The surface tension is hardly changed by the surfactant in this concentration; the surface tensions of the tap water and the 1-Pentanol solution are 71.5 mN/m and 69.5 mN/m, respectively. Room air is injected by a compressor to generate bubbles in the test section. A void fraction calculated from liquid and air flow rates is 0.7 %. A bubble injector composed many holes is

mounted on the upper wall of the channel at 1.75 m away from the channel inlet. Two types of the injector are adopted to maintain ranges of bubble size, from 3 mm to 13 mm, near the injector; one is composed large holes,  $6 \times \Phi 4$  mm, and another is composed relatively small holes,  $13 \times \Phi 1$  mm. If the same type of injector is used in the surfactant solution, the injector generates smaller bubbles than that in the tap water. An ultrasonic (US) transducer for detecting bubbles is located on 1, 2 or 3 m from the injector in streamwise direction on outer surface of the upper wall. The transducer is connected in parallel with an Ultrasonic Velocity Profiler (UVP) and a data logger. Conditions for instrument are shown in Tab. 1. The data logger is adopted to record echo signal with a high time resolution. Considering relation among the diameter of US beam, the bubble size distribution and the traveling velocity of bubbles in real situations, the high time resolution higher than that of the UVP is required to recognize individual bubbles. In the developing the bubble detecting system, the UVP is used instead of an US generator to estimate effects of bubbles on the turbulent flow structure by analyzing velocity profiles of liquid phase in our future work. Bubbles are removed by swirling the fluid in a tank setting at the end of channel before returning to the inlet of the channel via a pump. In order to confirm reproducibility and obtain sufficient amount of data for statistical analyses, experimental run of a single condition is performed 30 times.

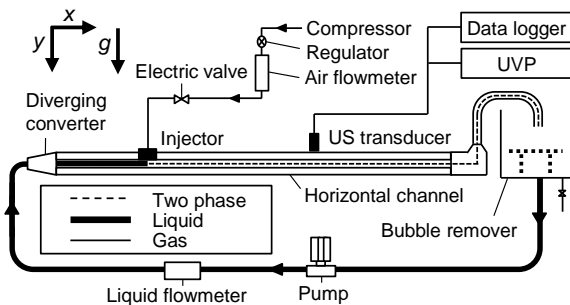

Figure 1: Schematic diagram of experimental facility

Table 1: Conditions for instrument

UVP	
US frequency	1 MHz
Number of cycle	2 -
Wavelength	1.5 mm
Pulse repetition frequency	10 kHz
Diameter of US beam	15 mm
Data logger	
Sampling rate	0.5 MHz
Number of sampling data	4000000 -

### 3 RESULTS AND DISCUSSIONS

The UVP is possible to measure time series liquid velocities and distribution of bubbles simultaneously. We already measured liquid velocities with bubbles and the results were reported in our previous paper [4]. We focus on an advection of detected bubbles by UVP with a high time resolution in this paper. Considering real situations, the time resolution is required at least 10 kHz for measuring advective bubbles having beneath ships.

#### 3.1 Detection of a bubble by ultrasonic echo

The echo amplitude in single phase flows obtained by the data logger is shown in Fig. 2(a). The highest value appears near the US transducer, shorter than 5 mm from the front face of the transducer, because of near field characteristics of ultrasound pulse close to the head of the transducer. If a bubble exists in this area, echo signal from the bubble hides behind the highest echo amplitude of the near field. Hence, the near field is avoided using the wall thickness, thicker than that of the field. The upper and bottom walls are detected as small peaks at 10 mm and 50 mm from the transducer. On the other hand, the echo amplitude at the upper wall, when bubble exist on the US beam, has higher value than that of single phase as shown in Fig. 2, because the US beam is reflected by bubbles, which are larger than the diameter of US beam [7] or wavelength of US [8]. Therefore, it is possible to detect bubbles using these two different patterns of the echo amplitude and a sample of results is shown in Fig. 3(b). In the sample condition, bubbles are also simultaneously detected by a line-scanned image taken by a camera, which is set above the US transducer (Fig. 3(a)). The camera was used in a short time to confirm an accuracy of detecting bubbles by the UVP because the high speed camera is unsuitable for recording for a long time comparing to the new system. Although detected bubbles by the camera are impossible to be statistically analyzed because samples are not enough, the accuracy of detecting bubbles by ultrasound is possible to confirm by comparing results of detected bubbles obtained from different methods. The success rate reaches 96.3 %. It means that this system is enough to practically use.

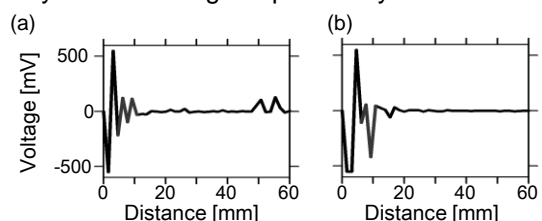

Figure 2: Echo amplitude obtained by the data logger; (a) without bubble and (b) with bubble, where the upper and bottom walls are located at 10 mm and 50 mm from

the transducer

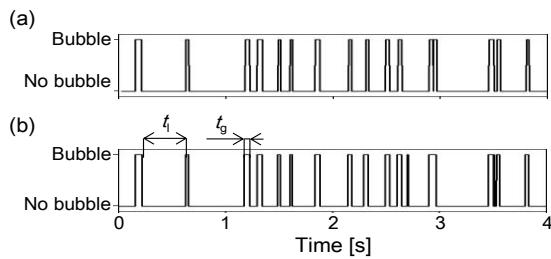

Figure 3: Detected bubbles obtained from different methods; (a) line-scanned image and (b) echo signal, where  $t_b$  and  $t_i$  are passing time of a bubble and time interval between bubbles, respectively

### 3.2 State of advective bubbles in downstream

Figure 4 and 5 show distributions of bubbles' chord length ( $l_b$ ) in tap water and 1-Pentanol solution, respectively.  $l_b$  is defined as  $l_b = Ut_b$ , where  $U$  and  $t_b$  are respectively a bulk liquid velocity and a passing time of bubbles (See Fig. 3(b)). In this experiment, a traveling velocity of bubbles is the same as the bulk liquid velocity. Although two kinds of working fluid have different surface tension, the chord length of bubbles has almost same distribution and the most existing chord length of bubbles is 5 mm in the both of tap water and 1-Pentanol solution in upstream region, 1 m away from the injector. It is because the injector with different size of holes is adopted in each working fluid. Bubbles in the tap water are coalesced until that they reach 2 m away from the injector and we cannot find typical peaks on Fig. 4(b). On the other hand, the distribution of bubbles in the surfactant solution is maintained in downstream because of prevented coalescences of bubbles by effects of contamination (Fig. 5(b) and (c)).

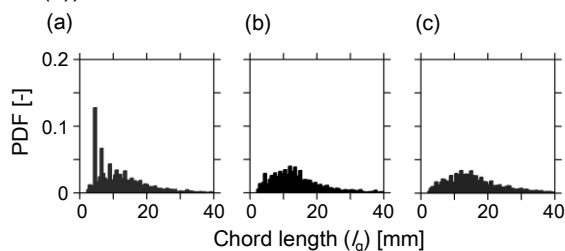

Figure 4: Distribution of bubbles' chord length in tap water; (a) 1 m, (b) 2 m and (c) 3 m from the injector

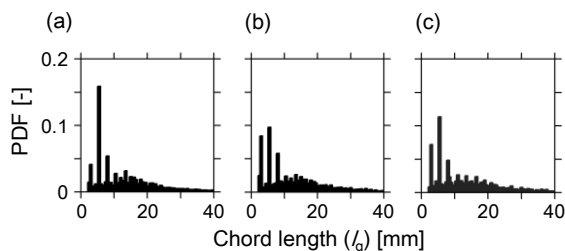

Figure 5: Distribution of bubbles' chord length with 1-Pentanol solution; (a) 1 m, (b) 2 m and (c) 3 m from the injector

Distributions of distance between bubbles ( $l_i$ ) in tap water and 1-Pentanol solution are shown in Fig. 6 and 7, respectively.  $l_i$  is defined as  $l_i = Ut_i$ , where  $t_i$  is a time interval between bubbles (See Fig. 3(b)). The distances obtained at 1 m away from the injector in both working fluids are almost shorter than 100 mm and several times longer than chord lengths of bubbles (Fig. 6(a) and Fig. 7(a)). The distances between bubbles in the tap water become longer at a downstream by coalescences of bubbles and have wide distribution in the region (Fig. 6(b)). After that the distribution has no significant change (Fig. 6(c)). Considering distributions of the bubble size and the distance in the tap water, bubbles in this condition is unstable until 2 m from the injector. On the other hand, the distribution of distance between bubbles with surfactant solution is maintained in all region of the channel.

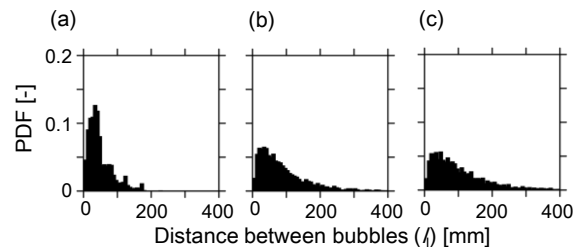

Figure 6: Distribution of distance between bubbles in tap water; (a) 1 m, (b) 2 m and (c) 3 m from the injector

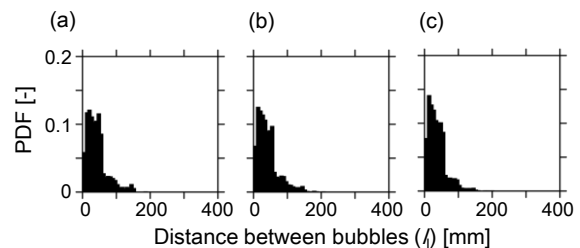

Figure 7: Distribution of distance between bubbles with 1-Pentanol solution; (a) 1 m, (b) 2 m and (c) 3 m from the injector

Time interval between two neighbor bubbles, indicated as  $t_i$  in Fig. 3(b), is analyzed by fitting to the Poisson distribution to understand an effect caused by bubbles that have passed through a same place in the past. The effect is termed bubble-neighboring effect in this paper. If a distribution of the interval obeys the Poisson distribution, it statistically indicates that bubbles are randomly passing and have no bubble-neighboring effect. To confirm that distribution of the interval corresponds to the Poisson distribution, cumulative distributions of the interval, sorted in descending order, are assessed. The result is shown in Fig. 7. The Poisson distribution gives a negative linear slope in the cumulative distribution in semi-logarithmic expression [9]. Bubbles in the tap water pass through randomly in the downstream region which is further than 2 m

from the injector (Fig. 7(a)). On the other hand, bubbles in the 1-Pentanol solution accompany the bubble-neighboring effect, proved by the cumulative distribution in the solution deviated from the Poisson distribution.

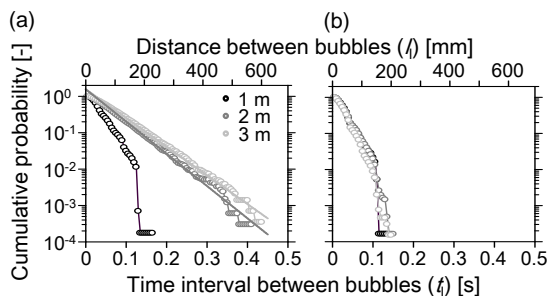

Figure 7: Cumulative probability of interval between bubbles; (a) tap water and (b) with 1-Pentanol solution

These results, which are the chord length of bubbles, the distance between bubbles and the randomness of passing bubbles, suggest that a periodicity exists when bubbles pass through in the 1-Pentanol solution. Power spectra calculated by Walsh transformation are shown in Fig. 8 and 9 for tap water and 1-Pentanol, respectively. The Walsh transformation is possible to avoid noise of a power spectrum at high frequency, which is occurred when a square wave analyzes by Fourier transform. Excepting the downstream region in the tap water, all graphs have peaks at 25 Hz. It is supposed that this frequency occurs by separating of bubbles from the injector.

All analysis means that the surfactant maintains states of bubbles on all regions in the channel flow by preventing the coalescence of bubbles. Furthermore, the distribution of time interval between bubbles does not obey the Poisson distribution at  $t \sim 0.1$  s, i.e. about 10 Hz. Although no peak appears near the frequency in the power

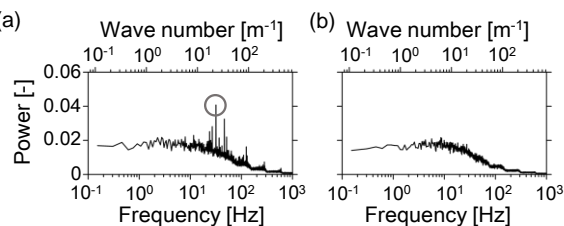

Figure 8: Frequency analysis by Walsh transformation with tap water; (a) 1 m and (b) 2 m from the injector

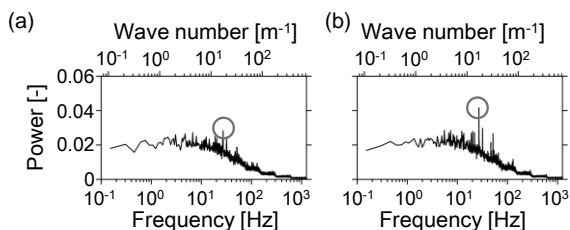

Figure 9: Frequency analysis by Walsh transformation with 1-Pentanol solution; (a) 1 m and (b) 3 m from the injector

spectra, it suggests that a fluctuation of void fraction, composed lower frequencies than 10 Hz, exists in the channel flow with the surfactant solution. Hence, if coalescence of bubbles is prevented, promoting drag reduction at a large vessel by the fluctuation of void fraction at bubble injecting is possible. Fortunately, almost large vessels are sailing on the sea and the sea water prevents the coalescence of bubbles.

## 4 SUMMARY

We performed a study for detecting bubbles in closed channel flow with high time resolution by echo signal of ultrasound obtained by a data logger. Ultrasound is reflected at bubble surface and it gives us a high echo amplitude. Detecting bubbles using different patterns of the echo amplitude has over 96 % in accuracy comparing with detecting bubbles by a line-scanned image.

Advective bubbles in the tap water and surfactant solution were investigated statistically by this technique at three locations in a downstream. In the tap water, distributions of bubble size and distance between bubbles are altered by coalescence of bubbles in the turbulent channel flow. And finally, bubbles are advected randomly on downstream region. On the other hand, the surfactant maintains states of a bubbly flow from an upstream region to a downstream region by preventing coalescence of bubbles. Furthermore, a fluctuation of void fraction, composed lower frequencies, exists in this condition and promoting drag reduction is expected using the fluctuation.

## REFERENCES

- [1] Ceccio S.L.: Frictional drag reduction of external flows with bubble and gas injection, *Annu. Rev. Fluid Mech.* 42 (2010), 183-203.
- [2] Hoang C.L. et. al.: Full scale experiment for frictional resistance reduction using air lubrication method, *Proc. ISOPE* (2009), 812-817.
- [3] Oishi et. al.: Frictional drag reduction by wavy advection of deformable bubbles, *J. Phys.: Conf. Ser.* 147 (2009), 012020.
- [4] Park H.J. et. al.: Turbulent shear control with oscillatory bubble injection, *J. Phys.: Conf. Ser.* 147 (2009), 012037.
- [5] Takeda Y., Ed.: *Ultrasonic Doppler Velocity Profiler for Fluid Flow*, Springer (2012).
- [6] Eric S. et. al.: Bubble-size distributions produced by wall injection of air into flowing freshwater, saltwater and surfactant solutions, *Exp. Fluids* 37 (2004), 802-810.
- [7] Matikainen L. et. al.: Ultrasonic system for the detection of transient liquid/gas interfaces using the pulse echo technique, *Rev. Sci. Instrum.* 57 (1986), 1661-1666.
- [8] Murai Y. et. al.: Ultrasonic detection of moving interfaces in gas-liquid two-phase flow, *Flow Meas. Instrum.* 21 (2010), 356-366.
- [9] Sreenivasan K.R. et. al.: Mean wind and its reversal in thermal convection, *Phys. Rev. E* 65 (2002), 056306.