

# Accuracy evaluation of a crossed beam double element transducer for ultrasound velocity profiler application

Fábio R. Coutinho, César Y. Ofuchi, Lúcia V. R. de Arruda, Flávio Neves Jr, Rigoberto E. M. Morales

Federal University of Technology - Paraná (UTFPR), Campus Curitiba, Brazil



Ultrasonic velocity profiler (UVP) is usually limited to a single element transducers generally operating in pulse-echo mode. Dual element transducer employs separate transmitting and receiving elements, in a crossed beam design, which makes more sensitive to echoes from irregular reflectors. Been applied to non destructive test for several years, this type of transducer is found to be very reliable and it is available in different frequencies and pulse voltages. In this work we compare the use of a dual element, 5 MHz, transducer, with a 4 MHz single element transducer. Experiments were carried out using a single phase liquid pipe flow in a turbulent regime. Ultrasound velocity profile is estimated, simultaneously, from both transducers, for 0.5 m/s, 0.7 m/s and 1.0 m/s of liquid superficial velocity. Accuracy performance is evaluated by computing mean liquid velocity and variance from velocity spatiotemporal map for 5 seconds of data acquisition.

**Keywords:** Ultrasonic velocity profile, Dual element transducer, single phase flow, turbulent flow.

## 1 INTRODUCTION

With the exception of high-viscosity fluid flow in small diameter pipes, internal flow is generally turbulent. Analytic solutions for turbulent flow are difficult to obtain and semi-empirical methods are usually adopted. Therefore accurate measurement techniques for this kind of flow are mandatory. Velocity profile estimation allows computation of shear stress, pressure drop and volumetric flow. Ultrasound velocity profile measurement is a in-line measurement, which can be applied to opaque liquid and gives high spatiotemporal resolution [1]. The work in [2] shows that ultrasound velocity estimation can be used to accurately measure the mean velocity profile of turbulent flow. UVP measurements are usually limited to single element transducers operating in pulse-echo mode. Dual-element ultrasonic transducers have two independent piezoelectric crystals to perform pulse excitation and reception separately. Usually it is assembled in a crossed beam design, which makes more sensitive to echoes from irregular reflectors. The use of separate elements for transmission and reception allows simple hardware circuit implementation for excitation and reception of ultrasonic pulses. In this work we evaluate a dual element transducer to be used for velocity profile estimation of a turbulent water pipe flow. Results are compared to a velocity profile estimated using a single element transducer in pulse-echo mode.

## 2 METHODOLOGY

### 2.1 Turbulent flow velocity profile model

There are numerous empirical approaches to calculate velocity profile in turbulent flow. Power-law velocity profile is the most used and simple

and it is expressed as [3]

$$\bar{u}(r) = U_{\max} \left( 1 - \frac{r}{R} \right)^{1/n}, \quad (1)$$

where  $U_{\max}$  is the maximum velocity in turbulent pipe flow evaluated at  $r=0$ ,  $R$  is the pipe inner radius and the exponent  $n$  depends on the Reynolds number through the relation [4]

$$n = -1.7 + 1.8 \log R_e, \quad (2)$$

which is valid for  $R_e > 20000$ .

### 2.2 Accuracy on shape reproducibility

High order moments will be used to evaluate shape reproducibility of estimated velocity profile as

$$M_n = \int_{-\infty}^{+\infty} \bar{u}(r) r^n dr, \quad (3)$$

For simplicity the profile will be considered symmetric and therefore only the zeroth moment (spatial mean velocity),  $M_2$  is the (variance) and  $M_4$  (flatness) will be computed.

### 2.3 Measurement System

An ultrasound velocity measurement system was build. Transducer excitation and echo reception was done by a commercial pulser/receiver from Olympus model 5077PR. This equipment allows selection of pulse-echo or dual element mode, analog gain for reception, but is limited to 1-cycle pulse. An acquisition board (NI-5105) digitized the received ultrasound signal. A Labview program controls data acquisition and storing. Matlab scripts communicate with Labview and perform velocity estimation by means of a phase shift method. Input and output synchronization signals

are treated by a digital input/output board (NI USB 6211). In this way, two independent measurement systems, one in pulse-echo mode and a second using a dual element transducer, can start acquisition simultaneously.

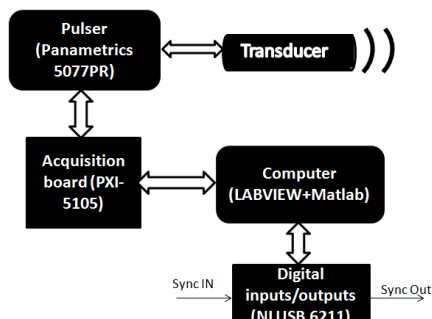

Figure 1: Block diagram of velocity measurement system build.

## 2.4 Experimental Setup

Tracer particles of 80  $\mu\text{m}$  to 200  $\mu\text{m}$  (EMS GRILTECH 1A P82), with 1.07  $\text{g}/\text{cm}^3$  was added to the water tank, Figure 2(i), to a concentration of 4 g/l. Fluid is circulated by a centrifugal pump, (ii), driven by a frequency inverter, (iii), into an 25.9-mm inner diameter, Plexiglas pipe. Water flow rate is measured Coriolis-type flow meter, (iv), which includes an RTD for temperature measurements. Water reservoir temperature is also measured by a thermocouple, Single element, 4 Mhz, 5-mm active diameter transducer from Metflow was mounted at 164D in measurement station 1, (vi). Measurement station 2 comprises of a dual element, 5 MHz, 6.35-mm active diameter transducer (model DHC 711RM) positioned at 170D.

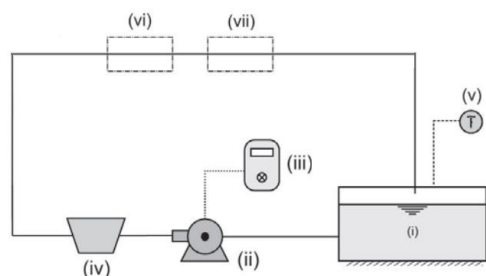

Figure 2: Experimental set-up. (i) water tank, (ii) pump, (iii) inverter, (iv) Coriolis-type flow meter, (v) temperature sensor, (vi) measurement station 1 (vii) measurement station 2.

Transducers were mounted beneath the channel at  $5.6^\circ$  and  $5^\circ$ , with respect to the vertical axis, at measurement station 1 and 2, respectively (Figure 3). The 4 MHz transducer is immersed in water in order to have good contact between the transducer and the pipe (Figure 3). Since dual element transducer is not of immersion type, it was coupled using a Plexiglas wedge as show in Figure 4(a).

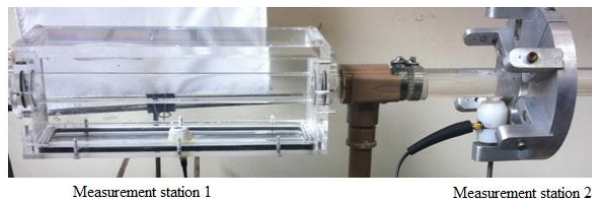

Figure 3: Picture of pipe section comprising measurement station 1 and 2.

Measurement system was configured to 0.62 mm of spatial resolution and 10 ms of temporal resolution. Velocity profile was estimated using 500 profiles or 5 seconds of acquired data. A pulse repetition frequency of 2 kHz was used. Echoes received were sampled at 60 MHz. Acquisition for 4 MHz and 5 MHz transducers were synced to start simultaneously. Velocity was computed using phase estimation method as proposed in [5]. Spatiotemporal velocity map estimated was filtered using a median filter with  $3 \times 3$  matrix size. Ultrasound velocity profile is estimated, simultaneously, from both transducers, for 0.5 m/s, 0.7 m/s and 1.0 m/s of liquid superficial velocity. Flow is assumed axis-symmetric therefore only half of profile is considered. To avoid the enlargement of measurement volume described in [1] it was used only the velocity profile near the transducer. Since this part of the measurement line present echoes due to ultrasound coupling to pipe wall, the stationary echo cancelling filter method proposed in [6] was used.

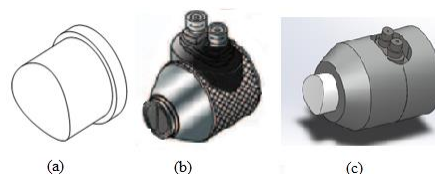

Figure 4: Transducer and wedge. In (a) wedge developed to couple transducer to pipe; (b) transducer mechanical drawings; (c) mechanical assembly.

## 3 RESULTS AND DISCUSSION

Shape reproducibility parameters computed are summarized in Table 1 and 2 for dual and single element transducer. For 0.5 and 0.7 m/s, mean spatial velocity,  $M_0$ , obtained for dual element presented better value than in single element. The reason for this is better understood analyzing the results in Figure 5-7. Velocity profile estimated by the 5 MHz transducer fluctuates over the theoretical profile line which contributes to a smaller error in  $M_0$ . Nevertheless, considering the mean  $M_0$  error (Table 1 and 2) both transducer arrangements perform similarly (0.96 and 1.06 for dual and single element transducer respectively). However, different from the single element transducer, the dual element profile presents a fluctuation (Figure 5-7). This behavior contributes

significantly to the values obtained in Tables 1 and 2. For the other shape parameters, mean error listed in Tables 1 and 2, mostly performs equally with the exception of the mean  $M_4$  error. The fourth order moment is related to the flatness of the profile. Since dual element transducer exhibits a large fluctuation in profile (Figure 5-7) relatively to single element, such behavior is reflected in a large mean  $M_4$  error for this transducer.

Table 1: Moments and maximum velocity absolute relative error for dual element transducer.

$J_L$ (m/s)	$M_0$ error (%)	$M_2$ error (%)	$M_4$ error (%)	$U_m$ error (%)
0.5	0.39	2.52	5.06	0.17
0.7	0.26	2.01	4.06	1.05
1.0	2.24	4.61	6.71	3.06
Mean	0.96	3.05	5.28	1.43

Table 2: Absolute relative error for profiles moments and maximum velocity for single element transducer.

$J_L$ (m/s)	$M_0$ error (%)	$M_2$ error (%)	$M_4$ error (%)	$U_m$ error (%)
0.5	1.30	2.49	5.86	3.21
0.7	0.82	3.77	6.54	-0.53
1.0	1.06	4.60	7.53	0.51
Mean	1.06	3.62	6.64	1.42

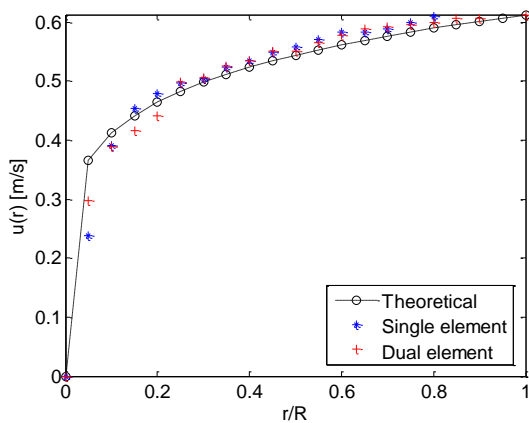

Figure 5: Comparison of velocity profile measured for  $J_L=0.5$  m/s.

It should be noted that the dual element profile points near the transducer ( $r/R < 0.25$ ) were all below the theoretical profile (Figure 5-7). As for single element, this profile underestimation near transducer does not occur. The difference in transducer coupling might be the root of this problem. The echoes generated at the wedge interface in the dual element transducer reduce the signal-to-noise ratio to signal acquired near the coupling, thus interfering in velocity estimation algorithm.

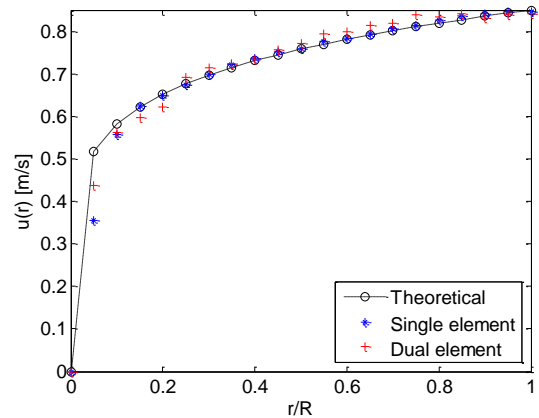

Figure 6: Comparison of velocity profile measured for  $J_L=0.7$  m/s.

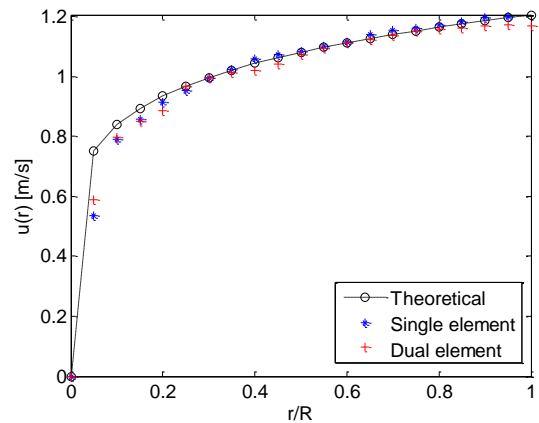

Figure 7: Comparison of velocity profile measured for  $J_L=1.0$  m/s.

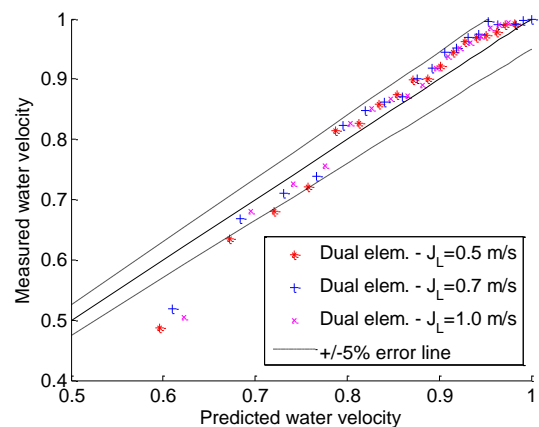

Figure 8: Comparison of predicted to measured water velocity for dual element transducer (5 MHz).

In Figure 8 and 9 the predicted water velocity by the measured are plotted for all  $J_L$  tested is shown. The fluctuations of values can be noticed by comparing these two graphs. In both Figures 8 and 9 most of measured data is in the 5% error

range. Velocity data points that presents bigger error values are the low velocities which may pertain to points measured in  $r/R < 0.04$  where power-law model is not applicable [3].

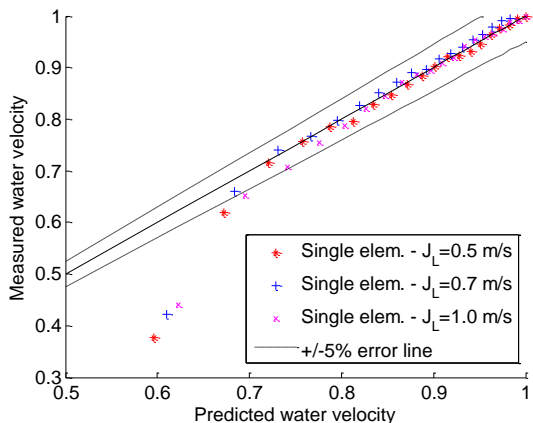

Figure 9: Comparison of predicted to measured water velocity for single element transducer (4 MHz).

In Figure 10, it was computed the mean of all profile estimation errors for each superficial velocity. For a fair comparison, the points below  $r/R < 0.04$  were excluded. The single element profile outperforms the dual element for 0.7 m/s and 1.0 m/s. The mean error between the three superficial velocities was also computed and is show in Figure 10. Thus, the single element transducer presented the best performance (1.66%) for profile shape reproducibility.

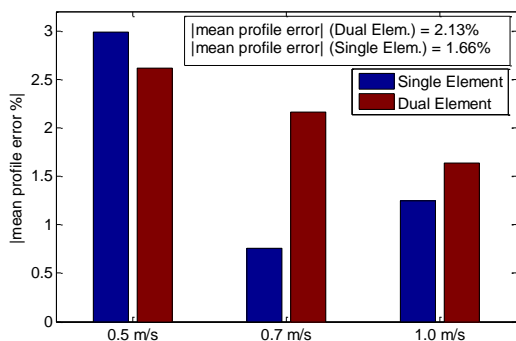

Figure 10: Comparison of mean profile error computed for each superficial velocity between single and dual element.

#### 4 SUMMARY

The application of dual element transducer for velocity profile estimation was proposed. For measuring spatial velocity mean, it was showed that this transducer can present a mean error of 0.96%. For velocity profile measurement, dual element transducer performed poorly than single element transducer. This was notable in the error of 6.64%(dual element) against 5.28% (single element) in the flatness profile shape parameter

( $M_4$ ). The mean profile error also support this conclusion. The proposed transducer showed a mean profile error of 2.13% while single element showed only 1.66%. The different coupling methods used (immersion and wedge, for single and dual element transducer respectively) may be the cause of the difference in profile estimation. In future work it should be tried to use a dual element which support immersion coupling.

#### REFERENCES

[1] Takeda Y: Ultrasonic Doppler fluid flow, Springer, Japan (2012).  
 [2] Taishi T, Kikura H, Aritomi M: Effect of the measurement volume in turbulent pipe flow measurement by ultrasonic velocity profile method. Experiments In Fluids, 32 (2002), 188-196.  
 [3] Fox R W, Pritchard P J, McDonald A T: Introduction to Fluid Mechanics, Wiley, USA (2006).  
 [4] Hinze J O: Turbulence, McGraw Hill, New York (1975).  
 [5] Takeda Y: Velocity profile measurement by ultrasonic Doppler method, Experimental Thermal and Fluid Science, 10 (1995), 444-453.  
 [6] Hoeks A P G, van der Vorst J J W, Dabekaussen A, Brands P J, Reneman R S: An efficient algorithm to remove low frequency Doppler signals in digital Doppler systems. Ultrasound Imaging. 13 (1991), 135-145